



Drop weight Impact Testing Machine



80kJ DWTT with automatic feeding and cooling



50kJ DWTT with semi-automatic feeding and cooling

Functions

This type of machine is especially designed for drop-weight tear tests of ferritic steels

Standards

GB/T 8363, ASTM E436, API RP 5L3, GOST 30456

Features

1. SIMENS PLC controls and touch screen provide high reliability and versatility.
2. Automatic specimen feeding and automatic positing
3. Frame structure is made of solid steel plate with high stability under impact
4. Striker is made of high strength steel plate with high impact resistance
5. Use chain to lift striker with high precision in height
6. Self-lock design for striker clamping
7. Full-closed safety shield
8. Special design tools for support change

Description

This machine is constructed by main frame, striker, striker lifting system, striker release/clamp device, specimen feeding system, damping device, specimen collecting device, guard screen, and control system.

Main frame

The bottom plate is made of solid steel plate, mass is up to 2100kg. Anvil is located onto the center of the bottom plate. Impact force onto the frame will rapidly transmit to the ground. As the impact force applies to the center of the main frame which is at the center of the foundation, foundation area is not so big (3mx3m), after long use, foundation will not decline by vibration, and horizontal level of the main frame will not change too. The main frame is supported by four columns. Each column is divided by upper and lower part. The lower part of the columns is cone-shape cast iron; the upper part is high strength steel pipe. Cone-shape of lower part has higher anti-decline ability than cylinder-shape. Cast iron has stronger vibration resistance and isolation, the vibration caused by impact force will not transmit to the top plate, therefore, the main frame has not apparent vibration for each impact test.

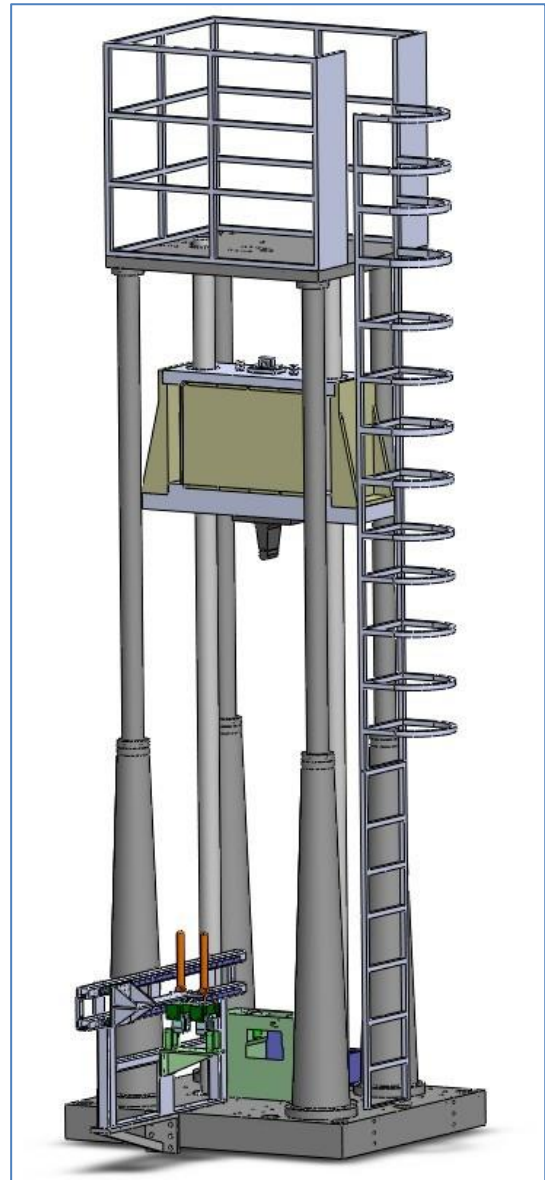

Specimen support and anvil

Anvil is split-type design, separated from support. It is simple to change the anvil after wearing. Anvil radius contacting specimen is R15.5mm, made of 6CrW2Si material, with HRC58~65 hardness after heat treatment. This material is one kind of tool steel, able to bear high speed impact, with high hardness. Various size of spacers are used to satisfy specimens with different thickness ranging 10-15mm, 15-20mm, 20-25mm, 25-30mm, 30-35mm, 35-40mm.

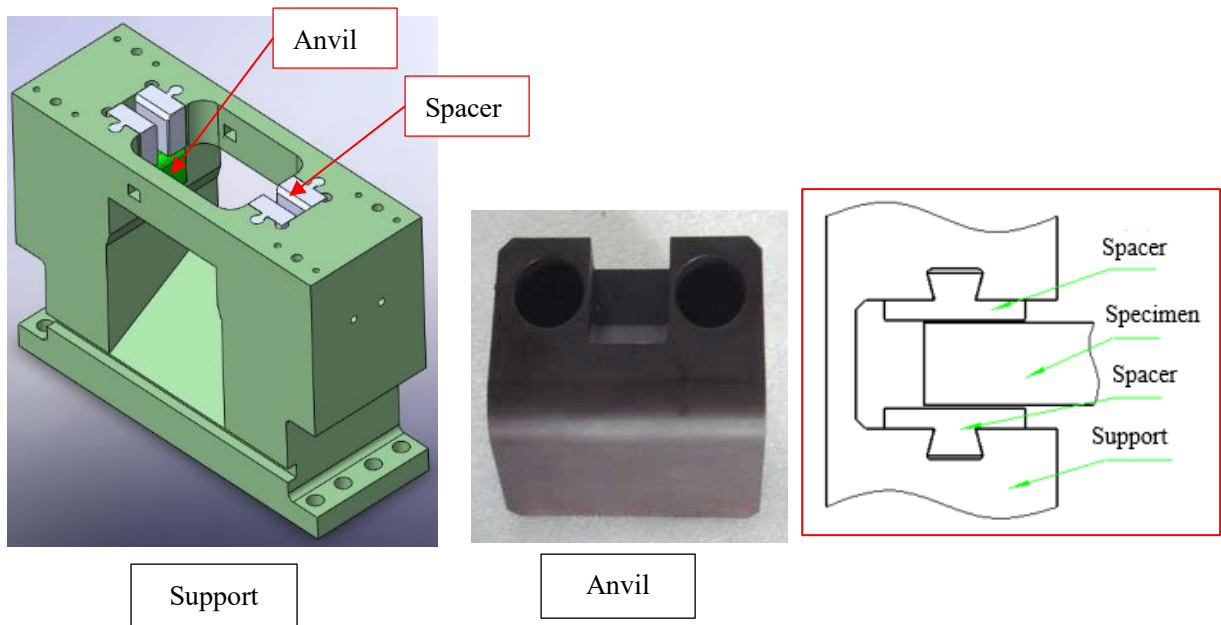

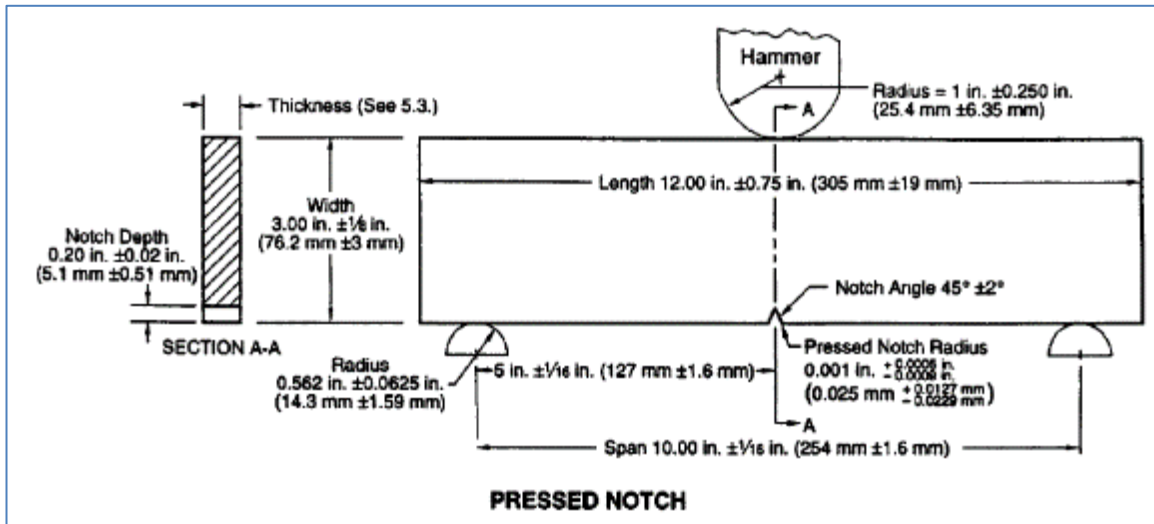

ASTM E436 & API RP*5L3

GB/T 8363: span is 254+1.5mm

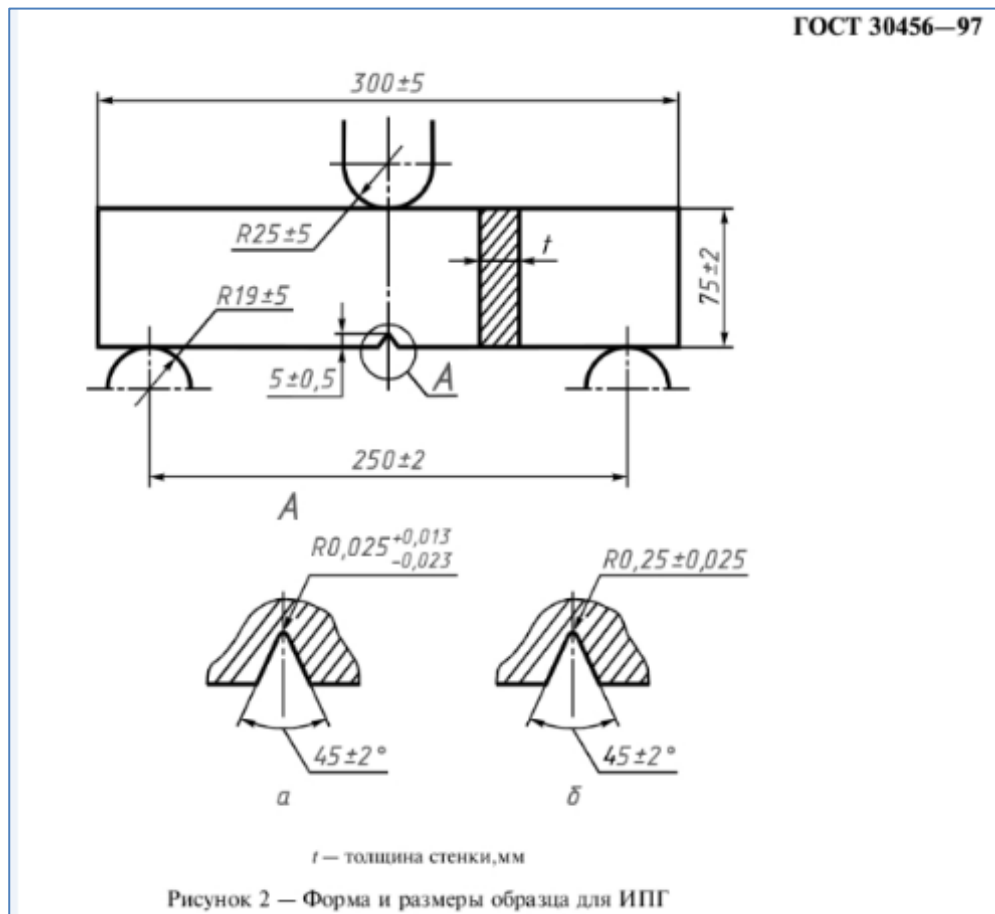

GOST 30456-97

Striker

Striker consists of a few parts, which are made of separately machined steel plate. It features high impact resistance ability. Junction between each part is fixed by pin, jointed by high strength screw bolt. Tup is made of alloy steel 6CrW2Si with good impact resistance, little abrasion, long service life, and simple to change. The weights are separate, easy to change. Connection between weights is alignment pin with reliability.

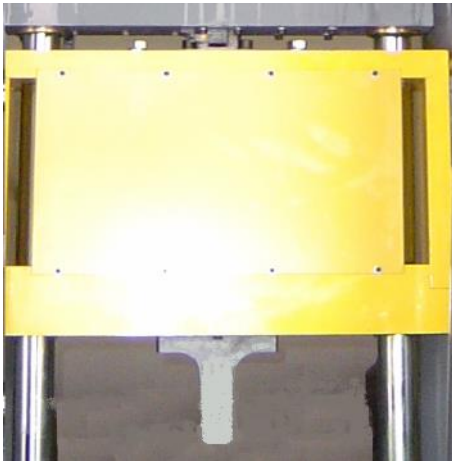

Striker



Weights assembly

Dead weights

Pin is used to lock weights

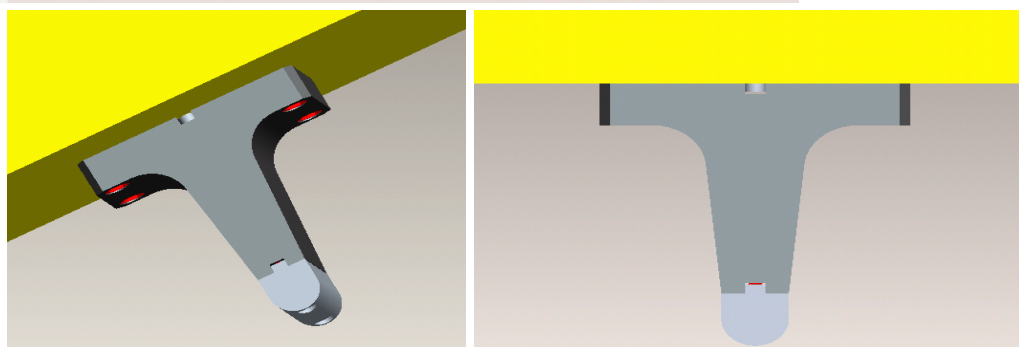
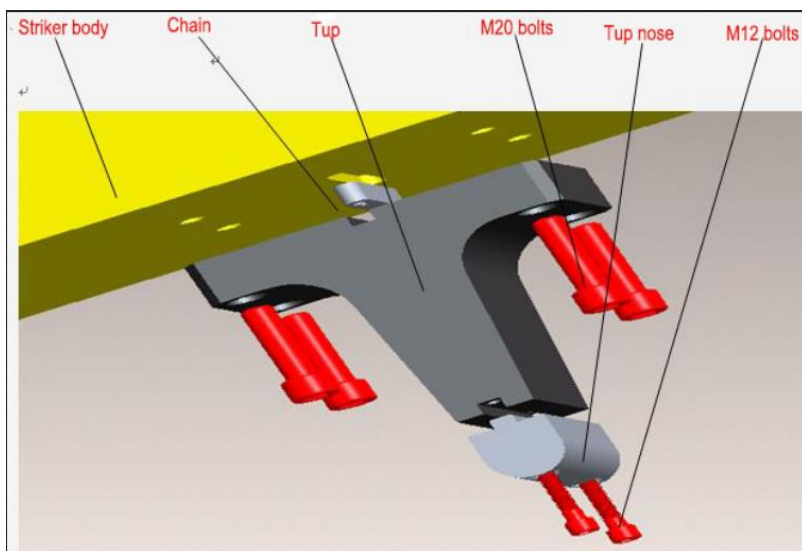

Tup nose assembly

Striker lifting system

Japanese made chain crane is used for lifting system, featuring light weight, small size, low noise and high stability.

Chain has less elasticity than wire rope, ensuring high accuracy in lifting height, with accuracy up to $\pm 3.5\text{mm}$.

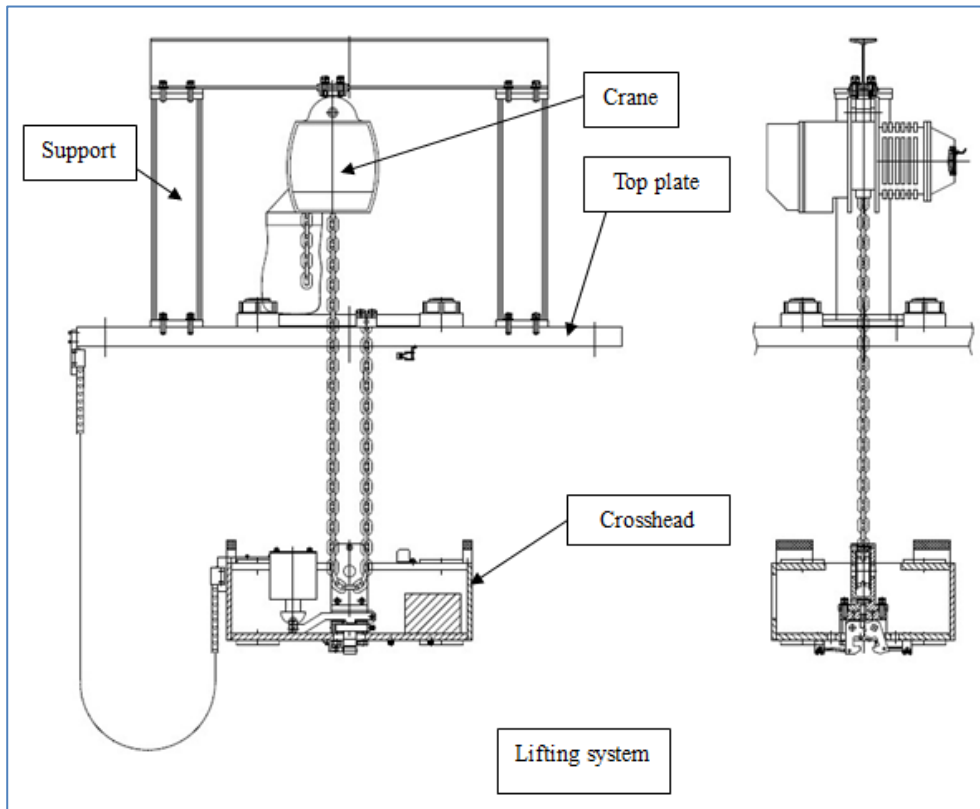

Striker release/clamp device

It is specially design and will automatically lock after clamping the striker. This device won't open caused by gravity even when the power is off. It is equipped with approach switch to detect the position. If striker is not clamped, crosshead won't move. It uses AC electromagnet for release of striker, no need of air supply, easy to mount and operate.

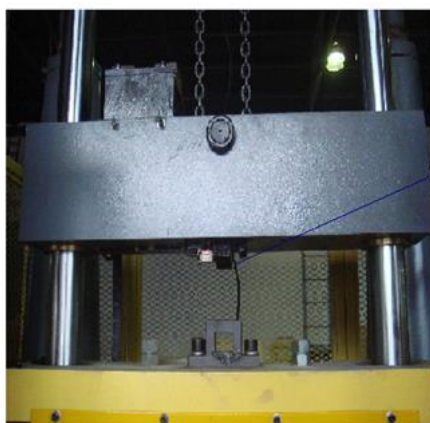

Before clamp



After clamp

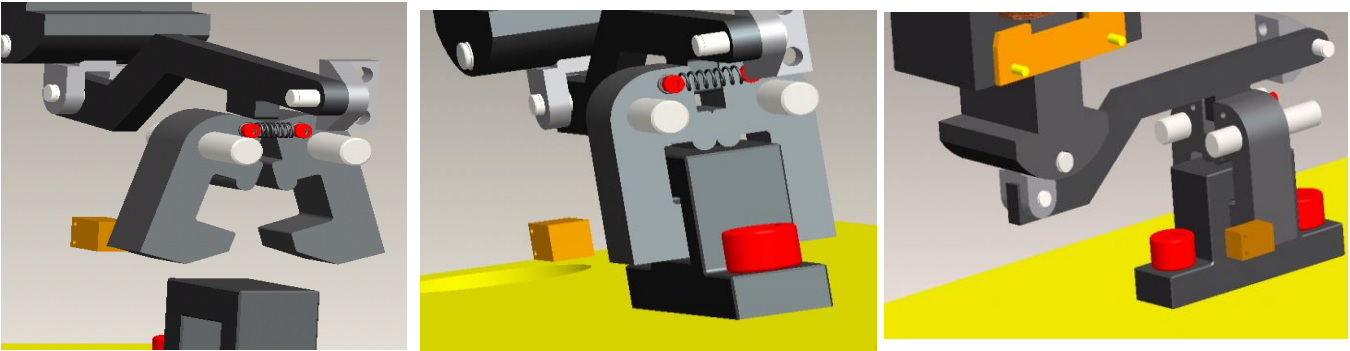

Semi-automatic specimen feeding device

Use motor to feed specimen within 5 seconds, fast, reliable and easy to operate. The frame is one body machined, without welding, with high strength. The frame tightly fits to the support, reducing the force on motor and extending the life of motor.

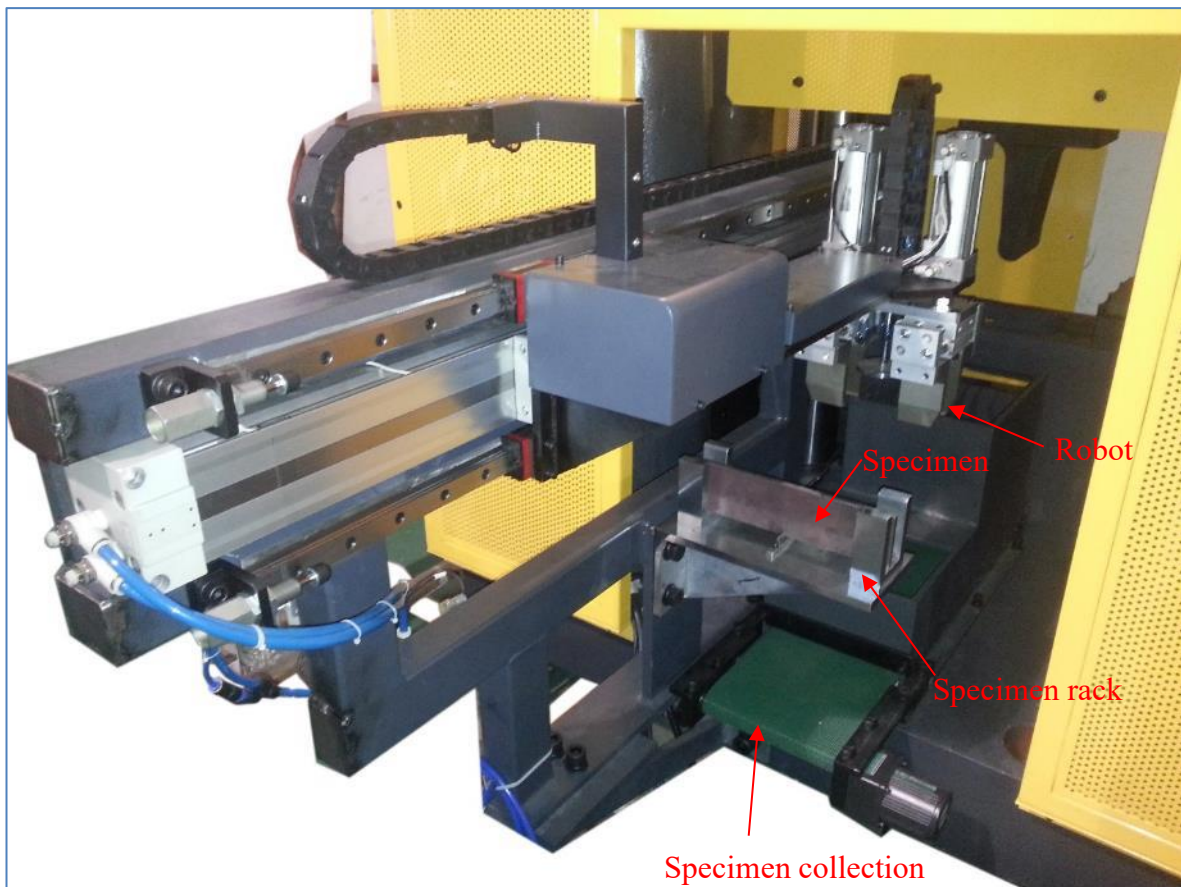

Damper

Damping travel: 100mm

Maximum damping energy: 15000J

As the test standard requires only one drop can tear the specimen, there is big residual energy after impact. Sometimes, the residual energy may reach several thousand or even more than ten thousand joules. Under low temperature impact test, the residual energy may be much higher. In this case a damping device is necessary and it will affect the service life of the impact machine. We specially design one kind of hydraulic damping device. Its structure especially the damping hole is strictly calculated and proofed after plenty of tests. Single damper can absorb up to ten thousand joules. The whole process is very stable, minimizing the impact to the machine. Both dampers have the same performance, extending the service life of the equipment.



Specimen collecting device

This device uses motor to drive rubber belt for sample collection after impact test. There I protection shield around the belt. After finishing test, broken specimen will drop onto the belt. After finishing each test, the collection device will run automatically and bring the specimen out, which improves the work efficiency and safety of operators.

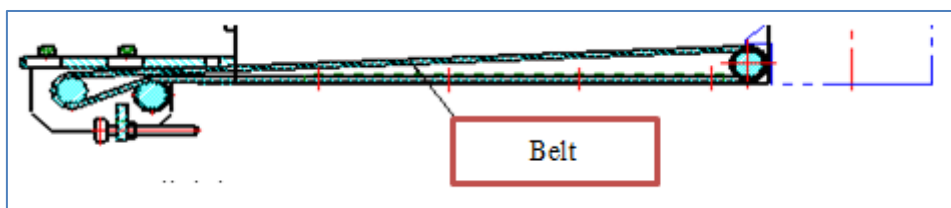

Safety

- There are full closed guard screen around the main frame to prevent broken specimen from splitting, also prevent operators from entry to the frame inside.
- Guard screen has door limit switch. When the door is open, the machine will lock automatically. Therefore it will avoid wrong operation and guarantee the safety of operator.
- Upper and lower limiter is to protect machine from damage.
- Lifting motor will brake automatically when power-off, to prevent striker from falling.
- Striker clamping hook has signal switch. If this switch has no detection of hook in correct position, lifting system won't work. Clamping hook has self-lock function, that is, external force can't release the striker if electromagnet is not activated.
- Two sleeve supports are supplied for maintenance use. When operator need change striker or specimen fixture, sleeve supports can be mounted onto damping cylinder and place striker body onto the supports. This will prevent sudden falling of striker body and protect operator.

Control system

- Control system in this machine provides automatic operations for striker lifting, zero positioning, specimen auto-feeding, impact, and striker clamping, which greatly reduces labor intensity and improves working efficiency and operating safety.
- Simens PLC programmable controller S7-300 series is used for the whole control system. PLC features high stability and reliability and strong anti-interference ability, avoiding any fault operation and improving safety of operators.
- 10' wide-view touch screen is used for terminal operating interface, simple to use. By switching different operation interface, it can perform test or maintenance. Working status monitoring and troubleshooting interface facilitates diagnose.
- Rotary encoder is used for sampling and controlling the height.
- Meanwhile this control system has an alarm function for such errors: specimen is not in the right position, striker is not locked, and guard screen is wrong, striker is not lifted to the correct position.
- Drop height can be input manually, or by inputting impact energy, the system can calculate the height automatically.



Working conditions

- Power supply: 3-phase, 5-line, VAC380V, 20kW; 1-phase 220VAC, 1kW.
- Air supply: 0.4~0.6Mpa, 50L/min.
- Work shop height: >6.5m
- Temperature: 10°C~35°C
- Grounding: resistance 3000 mm Ω.cm, soil resistance temperature 100°C-cm/w.

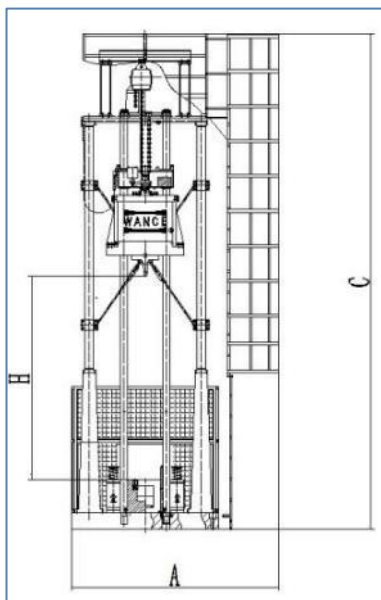

Model	Frame (A×B×C) mm	Drop height H(mm)
DIT304C	2562x2500x6430	3000
DIT504C	2600x1550x6110	2600
DIT804C	3000x3100x7300	3400
DIT105C	3000x3100x8000	4130



Technical parameters

Model	DIT304	DIT504	DIT804	DIT105
Type	C			
Maximum energy (J)	30000	50000	80000	100000
Minimum energy(J)	8000	20000	20000	20000
Tup mass (kg)	630	1600	1620	1620
Tup mass accuracy	±1%			
Weight mass (kg)	390 (13x30)	360 (12x30)	780 (26x30)	870 (29x30)
Weight mass accuracy	±0.5%			
Total weight of tup	1020	1960	2400	2490
Drop height(mm)	1275~3000	1275~2600	1275~3400	1275~4130
Velocity of drop (m/s)	5~7.67	5~7.13	5~8.16	5~9
Striker lifting speed (m/min)	4			
Height accuracy(mm)	≤±10			
Hardness of tup nose	HRC58~62			
Radius of tup nose(mm)	R25±0.1			
Hardness of support anvil	HRC58~62			
Alignment accuracy of center of tup nose, specimen and anvil center (mm)	≤±1.5			
Support anvil span (mm)	254±1.5 (ASTM E436 & API RP*5L3) 250±2 (GOST 30456-97)			
Specimen dimension (mm) (length x width x thickness)	(305±19) × (76.2±3) × (3~50)mm (ASTM E436 & API RP*5L3) (300±5) x (75±2) x (3~50)mm (GOST 30456-97)			
Weight (kg)	10000	15000	19000	20000
Power supply	3-phase, 5-line, AC 380V, 50Hz			
Power requirements	20A, 5kW			

Standard accessories

Description	Quantity
Main frame	1 set
Control cabinet with touch screen	1 set
Tup	1 set
Tup nose	1 set
Weights	1 set
Guard screen	1 set
Dampers	2 sets (20000J), 4 sets (more than 20000J)
Specimen semi-automatic feeding device	1 set
Support & anvil	1 set
Foundation bolt	4 sets

Optional accessories:

1. Automatic specimen feeding system, model: DWTT-AFD

This system can do all the jobs, sending the samples to cold temperature chamber, fetching the samples from the cold temperature chamber, sending the samples to the testing supporter, and collect the impacted samples out after the tests, it is fully automatic operation, which can maximally guarantee the safety of operators.

Working pressure: 0.6~0.8MPa

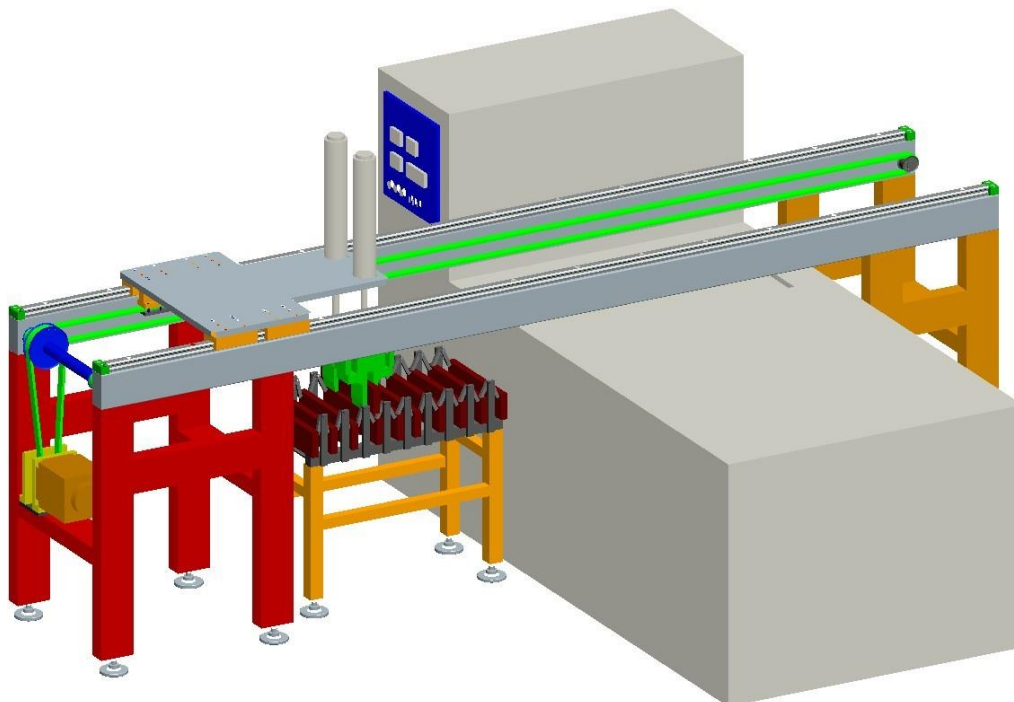



2. Automatic cooling chamber, model: CDW-80-55Z

It is used with automatic specimen feeding system.

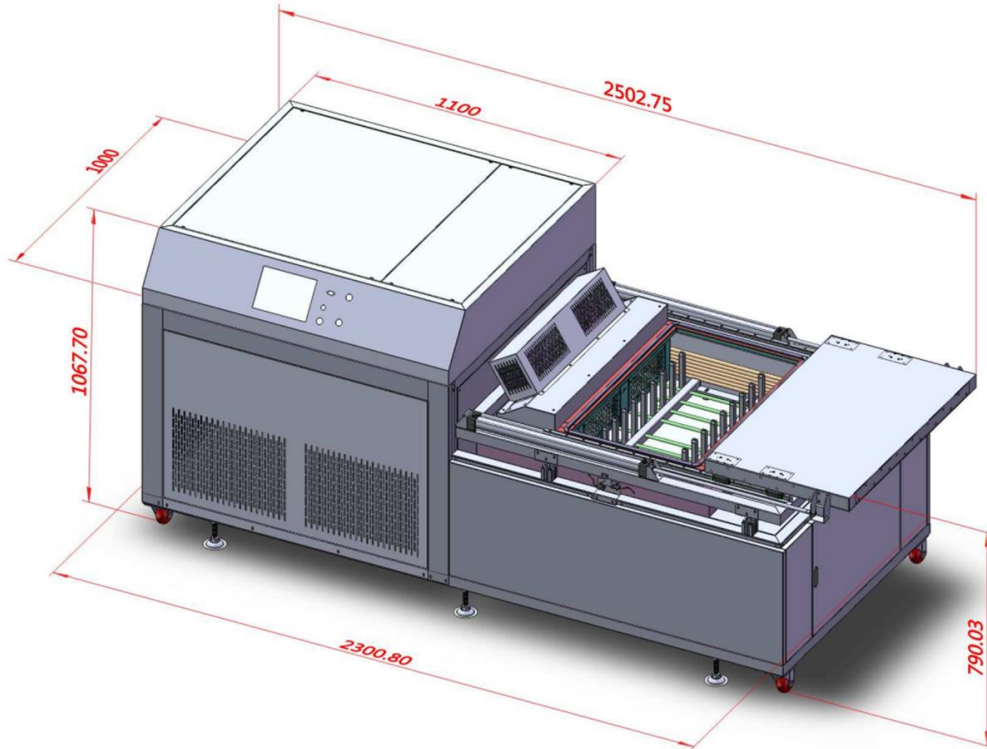

Model	CDW-80-55Z	
Temperature range	ambient ~ -80°C	
Constant temperature accuracy	±0.5°C	
Cooling speed (25°C room temperature)	Ambient~0°C	1.3°C/min
	0°C~-20°C	1.0°C/min
	-20°C~-40°C	0.8°C/min
	-40°C~-60°C(-40°C~-80°C)	0.6°C/min
Chamber inside size (depth x width x height)	710x650x175mm Total volume: 80L, with stirring	
Chamber working area size (depth x width x height)	710x440x175mm Volume: 55L, with copper tube for heat exchanging	
Effective chamber working area size (depth x width x height)	680x425x160mm Volume: 46L, without cooper tube	
Specimen quantity	8 pcs for DWTT specimen	
Cooling medium	absolute ethyl alcohol	
Control system	OMRON PLC	
Display	7" touch screen	
Door open	Pneumatic	
Stirring motor	90Wx2	
Power supply	3-phase, 380VAC, 50Hz, 16kW	



3. Standalone cooling chamber, model: CDW-80-73

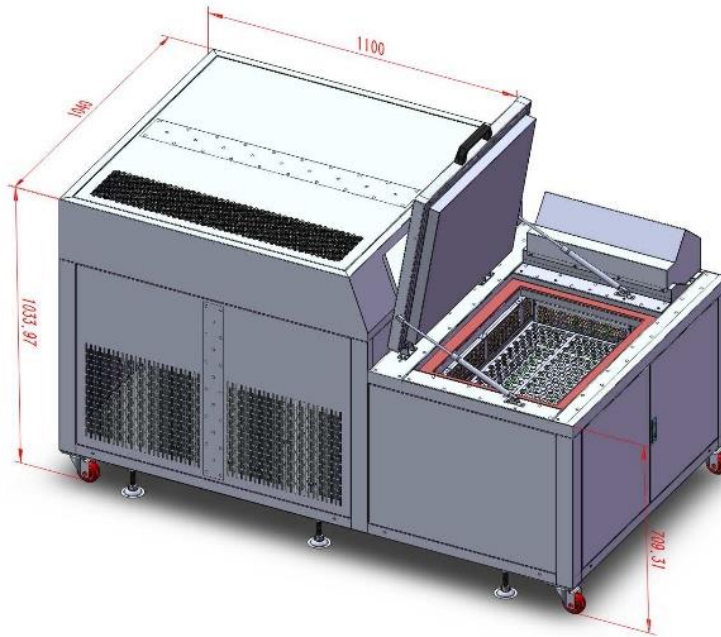

Model	CDW-80-73	
Temperature range	ambient ~ -80°C	
Constant temperature accuracy	±0.5°C	
Cooling speed (25°C room temperature)	Ambient~0°C	1.3°C/min
	0°C~-20°C	1.0°C/min
	-20°C~-40°C	0.8°C/min
	-40°C~-60°C(-40°C~-80°C)	0.6°C/min
Chamber inside size (depth x width x height)	760x440x220 mm Total volume: 73L, with stirring	
Chamber working area size (depth x width x height)	590x440x220 mm Volume: 57L, with copper tube for heat exchanging	
Effective chamber working area size (depth x width x height)	567x395x195mm Volume: 44L, without cooper tube	
Specimen rack	2 layers Upper: 500x325x85mm Lower: 500x335x85mm	
Specimen quantity	22 pcs (L305±5 x W76.2±1.5 x H5~50mm)	
Cooling medium	absolute ethyl alcohol	
Control system	OMRON PLC	
Display	7" touch screen	
Stirring motor	90Wx2	
Power supply	3-phase, 380VAC, 50Hz, 14kW	

4. Air compressor

Used to supply air for specimen feeding system.

Power: 2.2Kw

Air flow: 0.24M³/min

Rotation speed: 740 RPM

Air pressure: 0.8 MPa

Weight: 120 kg



5. DWTT specimen notching machine

Model: NSM401C

Description: This machine is specially designed for notch making of DWTT sample. It is driven by hydraulic system and controlled by electronics. The press knife uses hard alloy material CW6Mo5Cr4V2, with long life to use.

Comply with:

- ASTM E436-03<Standard Test Method for Drop-Weight Tear Tests of Ferritic Steels>
- API RP*5L3-96 <Conducting Drop-Weight Tear Tests on Line Pipe>

Parameters:

- **Max press force:** 1000kN
- **Sample size:**
(300±5)×(75±1.5)×(3~50)mm
(305±19) × (76.2±3) × (3~50)mm
- **Notch type:** V type, depth 5mm, angle 45°±2 °, arc radius r=0.025mm
- **Piston travel:** 120mm
- **Clearance between columns:** 410mm
- **Column diameter:** φ100mm
- **Compression space high:** 230mm
- **Loading method:** hydraulic
- **Max hydraulic pressure:** 16Mpa
- **Hydraulic oil:** 46# anti-wear hydraulic oil
- **Hydraulic oil volume:** 38L (prepared by the customer)
- **Machine dimension (L x W x H):** 1300mm x 420mm x 1460mm
- **Power supply:** 3-phase, VAC380V±10%, 50Hz, 2kW
- **Weight:** 400kg

